

New Fuse Block

**Wiring as shown on following slides.
Use your own imagination for your car.**

- **Brown** horn wires wired as in the original fuse block except that a 25 amp American fuse is used instead of a 50 amp British fuse.
- **White OD** wire located and wired on the fuse side of the block.
- **Other two White** wires located and wired on the common side of the block.
 - **It is not necessary to fuse the fuel pump at this location as it is fused in the boot (see that slide)**
- **Green** wires from the original bunch are wired to separate fuses and located by trial and error and/or a continuity tester.

New fuse Block Wiring

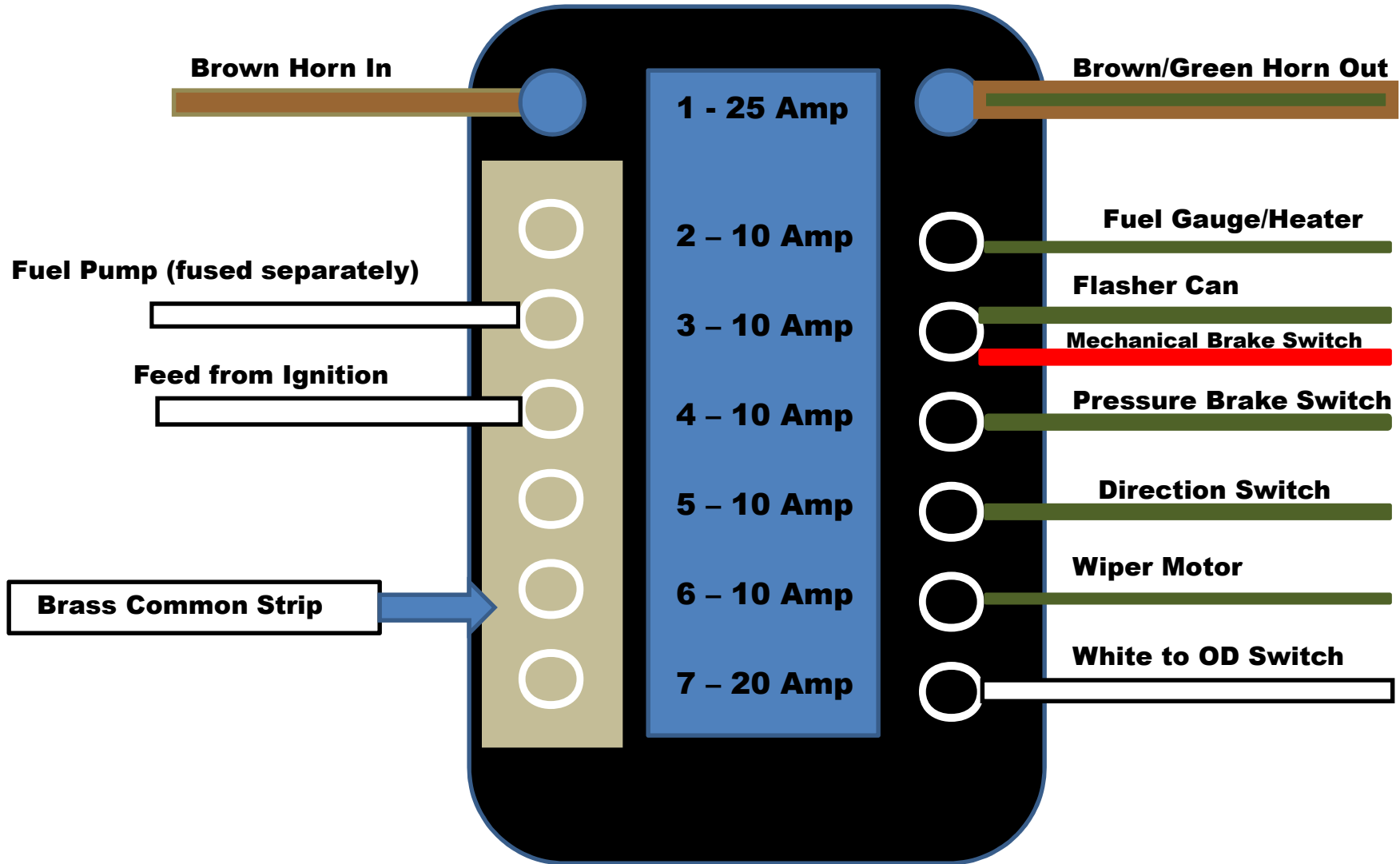

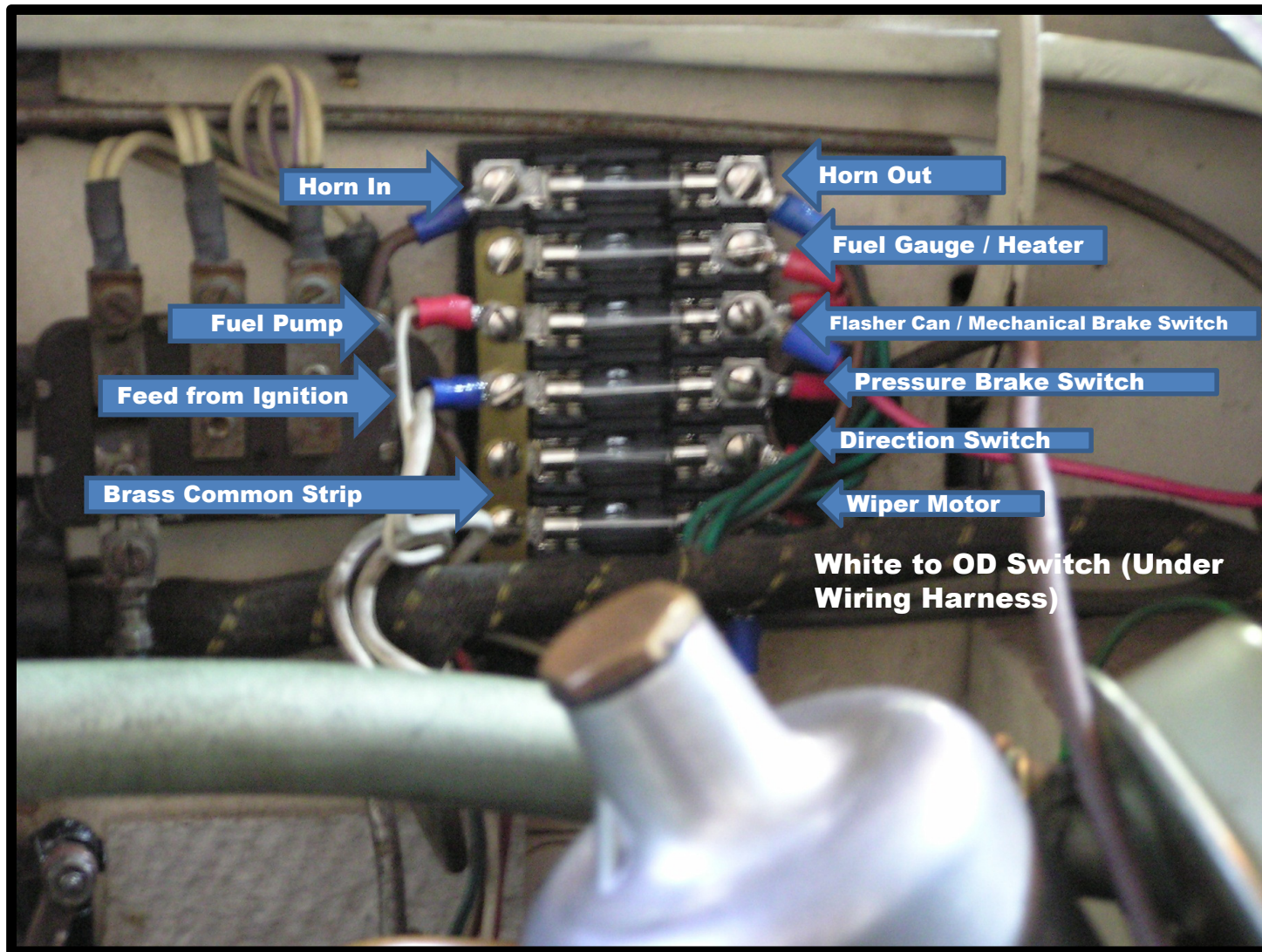

The mounting holes on this fuse block fit the existing firewall welded nuts.